

# ~ THE BECK ZAPPER ~

## Renewed Hope Against AIDS

**An inexpensive,  
build-it-yourself  
electromedical  
device is proving  
extremely  
successful in  
neutralising HIV,  
AIDS and other  
diseases.**

by Robert C. Beck, DSc  
© 1991-1997

Website: [www.rarebooks.net/beck/](http://www.rarebooks.net/beck/)

March 20, 1997 (last revision)

*Most men occasionally stumble over the truth, but most pick themselves up and continue on as if nothing had happened.*

— Winston Churchill

Dear fellow researcher,

This "theoretical" information is yours now. But before you start, you may wish to get a PCR test (count of active HIV cells in blood) and a second one 90 days after completion of neutralization. Some show dramatic drops; a few show negative HIV counts. However, in most cases, symptoms vanish or decrease dramatically regardless of test results.

Several subjects (but not all) have shown a *negative* PCR test (polymerase chain reaction; K. Mullis, 1983) after completion, indicating no more active HIV detectable in blood. But it's normal for common HIV *antibody* tests to remain the same even after complete remissions, just as you will always carry specific antibodies if you've once had childhood diseases like measles, chicken pox or mumps. Many other diseases including cancer may vanish with electrification and silver colloid ingestion plus ozone water detoxification.

This very slight and mild electrification of your blood does not kill any viruses or harm normal blood cells. Instead, the minute currents appear to alter and inhibit the ability of the outer protein layer of the virus to attach to lymphocytes (reverse transcriptase process). This blocks the binding of the HIV virus with the host cell (thymic-T lymphocyte; CD4 T-helper cells) so the virus is thought in effect to be neutralized, immobilized and eventually eliminated from the body. Rate of recovery is the product of current intensity multiplied by time of exposure (Kaali with Lyman and Merkatz, 1994). This communication describes a safe and tested procedure for interrupting HIV reproduction. But you *must* avoid ingesting any medicinal herbs, domestic or oriental, since blood electrification causes electroporation of cell membranes and can thus cause tremendous increase of molecular transport into cells, resulting occasionally in extreme and toxic overdosing. Allow one week to eliminate herbs and other medications from body before blood electrification (see J. C. Weaver, Harvard-MIT Division of Health Sciences and Technology, in *Journal of Cellular Biochemistry* 51:426-435, 1993).

With AIDS, be prepared for a temporary initial *drop* in T-cell count due to lysing (dissolution) of previously infected white cells by treatment-destroyed HIV and its subsequent scavenging by macrophages, since tests count both healthy and infected cells. Also, some patients do not test PCR-negative; however, practically all will experience a dramatic decrease in symptoms. T-cell counts CD4 (T4) may recover and continue to rise dramatically after a few months, since tests count both healthy and infected cells.

When discussing your recovery, please refer to all data and claims as "hypothetical" to avoid entanglement with FDA and legal constraints forbidding use of the word "cures".

If you follow instruction precisely, avoiding herbs and toxic medications, and detoxify properly, you may be symptom-free in a few months, safely and surely. We have numerous reports of complete recoveries when all instructions are followed.

Please share your results with me so as to assist others. Your name will not be used. We still have nothing for sale. So you have nothing to lose, since there is nothing to purchase except a few parts.

With highest regards, and good luck!

Bob Beck

**A PROPOSED EXPERIMENTAL/THEORETICAL,  
NONINVASIVE, NONPHARMACEUTICAL, *In Vivo*  
METHOD FOR RAPID NEUTRALIZATION OF  
HIV VIRUS IN HUMAN SUBJECTS**

Revision, March 20, 1997

by Robert C. Beck, DSc © 1991-1997

**I**n a remarkable discovery at Albert Einstein College of Medicine, New York City, in 1990, it was shown that a minute current (50 to 100 microamperes) can alter outer protein layers of HIV virus in a petri dish so as to prevent its later attachment to receptor sites (*Science News*, March 30, 1991, p. 207). It may also reverse Epstein-Barr (chronic fatigue syndrome), hepatitis and herpes B.

HIV-positive users of this enclosed information may expect a negative PCR test (no more HIV detectable in blood) after 30 days. This is reminiscent of a well-proven cure for snakebite, by application of electric current, that instantly neutralizes the venom's toxicity (*Lancet*, July 26, 1986, p. 229).

And there may be several other as yet undiscovered or untested viruses neutralizable with this discovery—perhaps, more surprisingly, even the common cold. This very simple and valid blood-clearing treatment offered great promise as a positive method for immobilizing known strains of HIV still present and contaminating some European and US blood bank reserve supplies.

It was further suggested that infected human HIV carriers could be cured by removing their blood, treating it electrically and returning it by methods similar to dialysis as described in US Patent #5,188,738. Dr S. Kaali, MD, projected that "years of testing will be in order before such an *in vitro* (blood removed for treatment) device can be made ready for widespread use" (*Longevity*, Dec. 1992).

This paper reveals an alternative "do-it-yourself" approach for electrifying/purifying blood with no dialysis, implants or medical intervention. In the writer's opinion, both blood and lymph can be cleared *in vivo* (which means blood isn't removed or skin ever penetrated), simply, rapidly and inexpensively, with similar but non-invasive techniques described herein. All are fully disclosed in this paper. Also

included are the proven schematic, parts lists, electrode construction details and complete instructions. Electronic and controlled electroporation approaches may well make vaccines, pharmaceuticals, supplements, herbs and diet therapies plus other proposed remedies obsolete, even if they worked and were universally available at no cost.

In a public lecture (Oct. 19, 1991), the writer proposed this theoretical do-it-yourself method for accomplishing HIV, parasite, fungus, virus, pathogen "neutralization" *in vivo*. Subsequently, his original modalities and protocols have been extensively peer-reviewed, refined, simplified and made universally affordable (under US\$75 for both devices, including batteries, when self-made). These two simple treatments used in tandem can potentially nullify well over 95% (and perhaps 100%) of known HIV

strains residing in blood, lymph and other body tissue and fluids.

The following is a summary of several years of offshore feedback with this non-iatrogenic, do-it-yourself, simple and inexpensive experimental solution to the ever-escalating AIDS dilemma. There are no known side-effects, since milliampere currents are much lower than those in FDA-approved TENS, CES and muscle stimulators which have been in use for many years. Battery replacement costs are minimal for a typical 21-day "spontaneous remission". No doctors, pharmaceuticals, shots, diets, medications or other interventions appear to be necessary.

One compact, battery-powered, blood-clearing instrument is basically a miniature relay driven by a timer chip set to ~4 hertz. Its 0 to 27 volt user-adjustable biphasic output minimizes electrode site irritation. The described system delivers stimulation through normally circulating blood via electrodes placed at selected sites (such as one electrode behind ankle bone on inside of foot and another on opposite foot) over the sural, popliteal, posterior tibial, or peroneal arteries where the subjects' blood vessels are

accessibly close to the surface, or on the wrist or arm. Optimum electrode positions are reliably located by feeling for strongest pulse. Microcurrent treatment is of such low amplitude that it creates no discomfort when used as directed, and is demonstrated to have no harmful side effects on healthy blood cells or tissue. However, a major obstacle to this simple and obvious solution is contrived aversion and disbelief.

Treatment for approximately 120 minutes per day for four or six weeks should, in the writer's opinion, effectively neutralize well over 95% of any HIV and, simultaneously, any other electrosensitive viruses, parasites, bacteria or fungi in blood. In heavy infections, shorter application times could prevent overloading patients with toxins: simply treat for a greater number of days or ingest ozonized water.

In time, the restored immune system plus ingested silver colloid may handle residual problems. In the special case of diabetically impaired circulation, longer treatment times may be indicated. Immobilized viruses may be expelled naturally through the kidneys and liver. More rapid neutralization is possible but not recommended because of potential excessive toxic elimination

reactions (Herxheimer's syndrome). T-cell counts may drop initially because of lysing and subsequent scavenging by macrophages, but should recover and increase after a few months. Even negative PCRs are sometimes reported.

Latent/germinating HIV reservoirs in the body's lymph or other tissue may theoretically be neutralized with a second and separate device by the strategy of generating a very high intensity (~10 kilogauss), short duration (~10  $\mu$ s) magnetic pulse of ~20 joules by discharging a modified strobe light's capacitor through an applicator coil held at body points over lymph nodes, thymus, kidneys, adenoids and other possible internal sites of latent infection. By the physics of Eddy current/back EMF "transformer action" (Lenz's law), the desired criterion of minimum current induced through infected tissue in the order of 100  $\mu$ A to 1 mA should be

**This paper reveals  
an alternative  
"do-it-yourself"  
approach for  
electrifying/  
purifying blood  
with no dialysis,  
implants or  
medical  
intervention.**

readily attained. Several pulses repeated at each site may insure a reliable "overkill" for successful disease neutralization.

A magnetic "pulser" is very inexpensive and simple to build. However, subjects must assume responsibility for their own health—a "heresy" in today's society where we're conditioned to look for answers only to a medical establishment that has no current knowledge remotely promising "cures" for numerous other well-known fatal diseases.

These "theoretical solutions" are being disclosed under constitutional freedom-of-speech guarantees in spite of extensively organized hostile opposition to non-pharmaceutical or inexpensive cures. Data can be legally offered only as "theoretical", and no medical claims can be made or implied. See your health professional!

Anyone at his discretion and assumed responsibility should be free to build, use (on himself) and network his "research" results. With these data an average, intelligent high school student should confidently be able to assemble both theoretical blood and tissue clearing modalities in about three hours and for a total investment of around US\$75.00. Components are widely available. If electronically unskilled, "busy" or technically illiterate, call an amateur radio supply store (yellow pages), or find a ham radio operator, hobbyist or TV repairman, or pay any kid on the block to do it for you.

After "spontaneous remissions", some users may wish to interest their doctors. But be advised that electronic cures may be vigorously suppressed or ignored because there is presently no credibility or drug cartel profit in this inexpensive AIDS solution. Also, the 1910 Rockefeller/Flexner Report attempted to discredit electromedicine in a conspiracy to inflate pharmaceutical profits.

I'm definitely not soliciting funds. This was independently developed by Bob Beck at his private expense and offered freely for "theoretical and informational purposes only" and with absolutely no profit motive.

Non-FDA-approved devices are illegal to use within the USA except via little-known FDA regulation loopholes whereby doctors and researchers are allowed to use anything on patients if they build it themselves (Code of Federal Regulations 21, § 807.65, Subpart D, Paragraphs {d} and {f}).

Although we will offer technical updates and always welcome feedback from users, please respect the writer's privacy and never attempt to contact him for additional help or construction information. Everything users need to know is included herein.

We have nothing for sale.

Bob Beck

## EXPERIMENTAL *In Vivo* BLOOD VIRUS, MICROBE, FUNGUS AND PARASITE ELIMINATION DEVICE

Revision, March 16, 1996  
by Robert C. Beck, DSc © 1993-1996

**Note:** These data are for informational, instructional and research purposes only, and are not to be construed as medical advice. Consult your licensed medical practitioner.

**CHANGES** since previous editions: Pulse repetition rate from 0.67 to ~4 Hz (not critical). C2 from 1.0 to 0.22  $\mu$ F. Voltage from 36 to 27 V. Treatment time increased to 2 hours daily for 21 to 30 days. Improved electrode design and single wrist electrode placement. SW2 added to extend battery life. There are no "errors" in this schematic. Hundreds have been constructed successfully when duplicated exactly without user-attempted "improvements".

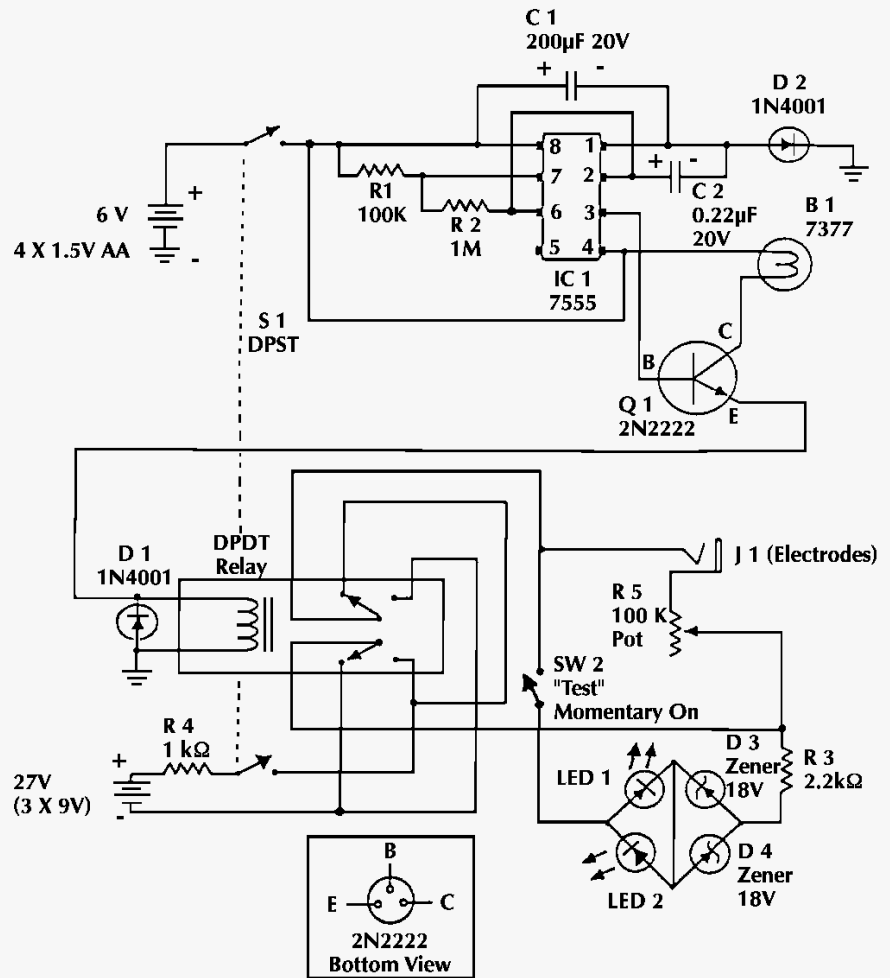

### SPECIAL PARTS

- B1: Filament-type incandescent bulb, 6.3V .075A, type 7377 (ballast & current limiter)
- Relay: 5V 50 coil, PCB mount DPDT, Selecta Switch SR15P207D1
- D3 & D4: Zener diodes, 18V, 2W, NTE 5027A
- R5: 100k 2W linear potentiometer, Caltronics P-68 or equivalent
- LED 1 & 2: Combined as bicolor red & green in same housing, Radio Shack #276-012
- SW2: "Test" SPST momentary on subminiature push-button, Radio Shack #275-1571

## PROPOSED THEORETICAL *IN-VIVO* BLOOD HIV, PATHOGEN AND PARASITE NEUTRALIZING DEVICE

COMPONENT DESCRIPTIONS, SOURCES AND CURRENT PRICES (March 1995)

Revision, March 13, 1996

by Robert C. Beck, DSc © 1991-1996

**Note:** These data are for theoretical, informational and instructional purposes only and are not to be construed as medical advice. Consult your licensed medical practitioner. Some builders have ego problems with following instructions (not invented here) and like to find "mistakes" or possible "improvements". Hundreds of devices have been built successfully, if duplicated exactly as shown. Do not expect this device to function optimally if any electrical changes or ego improvements are attempted.

7555 CMOS timer chip (generic)	IC1	\$ 1.80	
100 k ohm ( ) 3 watt (W) 5% resistor	R1	.07	
1 meg 3 W 5% resistor	R2	.07	
2.2 k 3 W 5% resistor	R3	.07	
1 k 3 W 5% resistor	R4	.07	
100 k linear taper pot, 1/2 watt Caltronics P-68	R5	2.56	
200 µF 20 V (or higher) electrolytic capacitor	C1	.45	
0.22 µF 20 V (or higher) tantalum capacitor	C2	.25	
1N4001 diode	2 required @ .15	D1 & D2	.30
18 V Zener diodes, 1/2 watt	2 required @ .79	D3 & D4	1.58 (NTE5027A)
NPN transistor, generic 2N2222	Q1	.30	
Bulb, 6.3 V 075 A, type 7377	B1	1.34	
Relay, 5 V 50 coil PCB Mount DPDT Selecta Switch SR15P207D1		5.45	
Misc. wire, solder, etc.		.50	
Custom-printed circuit board #PS-PCB		15.00	

Note: All 15 components listed above are available at Action Electronics, 1300 E. Edinger, Santa Ana CA 92705, USA, telephone (714) 547 5169. They also have a complete kit available for about \$80.00.

Bicolor LED red/green, Radio Shack #276-012	LED1	\$ 1.19	
Jack for electrode leads, #274-251, 3 for \$1.59	J1	.53	
DPDT switch, #275-626 or equiv. (used as DPST)	SW1	2.55	
SPST Submini momentary push button switch	SW2	.59	(ER-SW101 "Test")
Battery holder, 4 AA cells, Radio Shack #270-383		1.29	
4 Alkaline AA cell batteries, #23-552		2.89	
3 Alkaline 9-V batteries, type 1604, etc.		3.75	
3 9-V battery snaps (clip-on connectors), #270-325, pkg 5 for \$1.29		1.29	
Box, if used		2.29	

Note: The above items are generally available at local Radio Shack stores.

Lead wire with 3.5 mm plug, 6 ft, Mouser or Calrad Electronics	\$ .35	
Electrodes, stretch elastic, Velcro, cotton flannel, alligator clips, etc.	<u>± 5.00</u>	(see notes)
Total cost for all components for do-it-yourself project	\$49.24	

This design is basically a 7555 IC timer chip set for 50% duty cycle and ~3.9 Hz driving a subminiature relay. Electrode polarity continually reverses: ~1/4 second positive / 1/4 second negative. Frequency is not critical.

Patents applied for.

**Footnote:**

CODE OF FEDERAL REGULATIONS 21 § 807.65 Subpart D – Exemptions, Paragraphs {d} & {f}

Excludes and exempts from regulation:

"(d) Licensed practitioners, including physicians, dentists, and optometrists, who manufacture or otherwise alter devices solely for use in their practice."

"(f) Persons who manufacture, prepare, propagate, compound, or process devices solely for use in research, teaching, or analysis, and do not introduce such devices into commercial distribution."

Use of this device therefore appears legal and exempt from FDA regulations when you construct it yourself for research and/or use in your own practice! But double-check your local, county and state regulations for possible exceptions.

## EXPANDED INSTRUCTIONS FOR EXPERIMENTAL/ THEORETICAL HIV BLOOD NEUTRALIZATION Hypothetical Protocols for Experimental Sessions

Revision, March 20, 1997

by Robert C. Beck, DSc ©1991-1997

**P**RECAUTIONS. Do *not* use wrist-to-wrist with subjects with cardiac pacemakers. Any applied electrical signals may interfere with "demand"-type heart pacers and cause malfunction. Single wrist locations should be acceptable. Do *not* use on pregnant women or while driving or using hazardous machinery.

Users *must* avoid ingesting anything containing medicinal herbs (foreign or domestic) or potentially toxic medication, or nicotine, alcohol, recreational drugs, laxatives, tonics and certain vitamins, etc., for one week before starting, because blood electrification can cause electroporation which makes cell membranes pervious to small quantities of normally harmless chemicals in the plasma. The effect is the same as extreme overdosing, which may be lethal. (See Weaver, J. C., "Electroporation: A General Phenomenon for Manipulating Cells and Tissues", *Journal of Cellular Biochemistry* 51:426-435, 1993.) Effects can mimic increasing dosages manyfold. Both the magnetic pulser and blood purifier cause electroporation.

Do *not* place electrode pads over skin lesions, abrasions, new scars, cuts, eruptions or sunburn. Do *not* advance output amplitude to uncomfortable levels. All subjects will vary. Do *not* fall asleep while using. The magnetic pulser should be safe to use anywhere on the body or head.

Avoid ingesting alcohol 24 hours before using. Drink an 8-ounce glass of distilled water 15 minutes before and immediately following each session, and drink at least four additional glasses daily for flushing during "neutralization" and for one week thereafter. This is *imperative*. Ignoring this can cause systemic damage from unflushed toxic wastes. When absolutely essential drugs must be ingested, do so a few minutes after electrification, then wait 24 hours before the next session.

If the subject feels sluggish, faint, dizzy, headachy, light-headed or giddy, nauseous, bloated or has flu-like symptoms or rashes after exposures, reduce pulsing per session and/or shorten applications of electrification. Drink more water—preferably ozonized—to speed waste oxidation and disposal. Use extreme caution when treating patients with impaired kidney or liver function. Start slowly at first, like about 20 minutes per day, to reduce detoxification problems.

To avoid shock liability, use batteries only. Do *not* use any line-connected power supply, transformer, charger, battery eliminator, etc. with the blood-clearing device. However, line supplies are okay with well-insulated magnetic pulse generators (strobe lights).

Health professionals: avoid nicotine addicts, vegans and other unconsciously motivated death-wishers and their covert agendas of "defeat the healer". Tobacco, the most addictive (42 times

more so than heroin) and deadly substance of abuse known, disrupts normal cardiovascular function. True vegetarian diets are missing essential amino acids absolutely necessary for the successful rebuilding of AIDS-ravaged tissues. Secondary gains (sympathy/martyrdom, work avoidance, free benefits, financial assistance, etc.) play large roles with many AIDS patients. "Recovery guilt" as friends are dying has even precipitated suicide attempts masked as "accidents". Avoid such entanglements, since many have unconscious death wishes.

**SUPERIOR ELECTRODES.** Excellent, convenient and vastly superior electrodes, reusable indefinitely, can be made by butt-soldering lead wires to ends of 1-1/8-inch long by 3/32-inch-diameter blanks cut from type 316 stainless steel rods available from welding supply stores (e.g., Cameron Welding Supply, 11061 Dale Ave, Stanton, CA 90680). Use Stay Clean flux (zinc chloride/hydrochloric acid) before soldering.

Shrink-insulate *two* tight layers of tubing over soldered joints to prevent flexing/breaking and lead/copper ions from migrating. Wrap three or four turns of 100% cotton flannel around rods.

Spiral-wrap with strong thread starting from wire side to end. Tightly pinch cloth over the rod's end so as to leave no metal exposed by wrapping six or seven turns of thread *tightly* just off the end of the rod, then spiral-wrap back to start and tie tightly with four knots. Cut off excess cloth at end, close to pinch wraps.

Treat end windings and knots with clear fingernail polish or Fray Check® (fabric and sewing supply stores) to prevent unravelling. Soak in a strong solution of sea salt (not table salt) containing a little wetting agent like Kodak Photo Flow, ethylene glycol or 409 kitchen cleaner. Add a few drops of household bleach, silver colloid, etc., for disinfectant. Store solution for reuse.

Tape soaking-wet electrodes tightly over pulse sites with paper masking or Transpore™ tape, or with one-inch-wide stretch elastic bands with tabs of Velcro® at ends to fasten. Electrodes should closely conform precisely along blood vessels, not skewing ever so slightly over adjacent flesh. This insures better electrical conductivity paths to circulating blood and insures very low internal impedance (~2,000 watts). Rinse and blot-dry electrodes

and skin after each use. *Never* allow bare metal to touch skin, as this will cause burns manifested as small red craters that heal slowly. The objective is to get maximum current into blood vessels, not to leak it over to adjacent tissue.

**ELECTRODE PLACEMENTS.** Locate maximum pulse position (not to be confused with acupuncture, reflexology, Chapman points, etc.) on feet or wrists by feeling for maximum pulse on inside of ankle, approx. one inch below and to rear of ankle bone, then test along top center of instep. Place electrode on whichever pulse site on that foot that feels strongest. Scrub skin over chosen sites with mild soap and water or alcohol swab; wipe dry. Position the electrodes lengthwise along each left and

...blood electrification  
can cause electro-  
poration which makes  
cell membranes  
pervious to small  
quantities of normally  
harmless chemicals  
in the plasma.

right wrist's blood vessel. Note: with subjects having perfectly healthy hearts and not wearing pacers, it is convenient to use left wrist to right wrist exactly over ulnar arterial pulse paths instead of on feet. Recent (Dec. 1995) research suggests that placing both electrodes over different arteries on the same wrist works very well, avoids any current through heart, and is much more convenient and just as effective. An 8-inch-long, 1-inch-wide elastic stretch-band with two 1-inch lengths of wide Velcro® sewn to ends of opposite sides makes an excellent wristband for holding electrodes snugly in place.

With electrode cable unplugged, turn switch *on* and advance amplitude control to maximum. Push momentary SW2 "Test" switch and see that the red and green light-emitting diodes flash alternately. This verifies that polarity is reversing approx. four times per second (frequency is *not* critical) and that the batteries are still good. When LEDs don't light, replace all three 9-volt batteries. When the white incandescent bulb dims or appears yellowish, or relay isn't clicking, replace all four AA cells. Zener diodes will extinguish LEDs when the three 9-volt batteries' initial 27 volts drop below 18 volts after extended use. Never use any electrode larger than 1-1/8" long by 1/8" wide to avoid wasting current through surrounding tissue. Confine exactly over blood vessels only. Apply drops of salt water to each electrode's cotton cover approximately every 20 minutes to combat evaporation and insure optimum current flow. Later devices are solid-state, use only three batteries and no relays, and are much smaller.

Now rotate amplitude control to minimum (counter-clockwise) and plug in electrode cable. The subject now advances the dial slowly until he feels a "thumping" and tingling. Turn as high as tolerable, but don't advance amplitude to where it is ever uncomfortable. Adjust voltage periodically as he adapts or acclimatizes to current level after several minutes. If the subject perspires, skin resistance may decrease because of moisture, so setting to a lower voltage is indicated for comfort. Otherwise, it is normal to feel progressively less sensation with time. You may notice little or no sensation at full amplitude immediately, but feeling will begin building up to maximum after several minutes, at which time amplitude must be decreased.

Typical adapted electrode-to-electrode impedance is in the order of 2,000 W. Typical comfortable input (to skin) is ~3 mA, and maximum tolerable input (full amplitude) is ~7 mA, but this "reserve" margin, although harmless, is unnecessary and can be uncomfortable. Current flowing through blood is very much lower than this external input because of series resistance through skin, tissue and blood vessel walls, but 50 to 100 µA through blood is essential.

Apply blood neutralizer for about two hours daily for approx. two months. Use judgment here. The limiting factor is detoxification. Carefully monitor subject's reactions (discomfort, catarrh, skin eruptions, weeping exudates, rashes, boils, carbuncles, coated tongue, etc.). With very heavy infections, go more slowly so as not to overload the body's toxin disposal capability. With circulation-impaired diabetics, etc., you may wish to extend session times. Again, have the subject drink lots of water.

Recent changes in theoretical protocol being currently tested suggest following up the three weeks of treatments with a 24-

hours-per-day (around the clock) continuous electrification of blood for two days to deal a knockout blow to the remaining HIV's 1.2-day life cycle (Perelson, A., Los Alamos Biophysics Group, *Science Journal*, March 16, 1996). Remember to remoisten electrodes regularly. If you absolutely must ingest prescription drugs, do so immediately after turning off instrument and allow 24 hours before next treatment to let concentrations in blood plasma decay to lower levels.

Remember, if subjects ever feel sleepy, sluggish, listless, nauseous, faint, bloated or headachy, or have flu-like reactions, they may be neglecting sufficient water intake for flushing toxins. We interpret this as detoxification plus endorphin release due to electrification. Let them rest and stabilize for approx. 45 minutes before driving, if indicated. If this detoxing becomes oppressive, treat every second day. Treating at least 21 times should "fractionate" both juvenile and maturing HIV to overlap maximum neutralization sensitivity windows and interrupt "budding" occurring during HIV cells' development cycles.

Treatments are claimed to safely neutralize many other viruses, fungi, bacteria, parasites and microbes in blood. See US patents #5,091,152, #5,139,684, #5,188,738, #5,328,451 and others, as well as numerous valid medical studies which are presently little known or suppressed.

Also, ingesting a few ounces of approx. five parts per million of silver colloid solution daily can give subjects a "second intact immune system" and minimize or eliminate opportunistic infections during recovery phase. This miracle substance is pre-1938 technology and, unlike ozone, is considered immune from FDA harassment. Silver colloid can

easily be made at home electrolytically in minutes and in any desired quantities and parts-per-million strength for under one cent per gallon plus cost of water. It is ridiculous to purchase it for high prices. Colloid has no side effects and is known to eliminate rapidly or prevent hundreds of diseases. Silver colloids won't produce drug-resistant strains as will all other known antibiotics. No reasonable amount can overdose or injure users either topically, by ingestion or by medical professional injection.

**Treatments are claimed to safely neutralize many other viruses, fungi, bacteria, parasites, and microbes in blood.**

**FOR THOSE WHO DO NOT WISH TO MAKE THEIR OWN 'BECK ZAPPERS', THERE ARE PRE-MADE MODELS AVAILABLE. WE ARE AWARE THAT THE FOLLOWING BUSINESSES MAY BE ABLE TO ASSIST YOU WITH LOCATING SUCH A DEVICE:**

- **In Australia:** Natural Therapy Products, PO Box 252, Turramurra, NSW 2074, phone (02) 9983 1299; or Exclusive Products, PO Box 1000, Indooroopilly Centre, Qld 4068, phone (07) 3371 6126
- **In USA:** SOTA Instruments, Inc., phone 1800 24 0242 (toll free) or (604) 244 0214, website, [www.sota-inc.com](http://www.sota-inc.com)
- **In UK:** Commercial Science, 11 Hylands Close, Crawley, Sussex RH10 6RX, phone 01293 446244
- **In New Zealand:** Altered States, 4 Gundry Street, Newton, Auckland, phone (09) 309 6275